

QUANTUM QP100

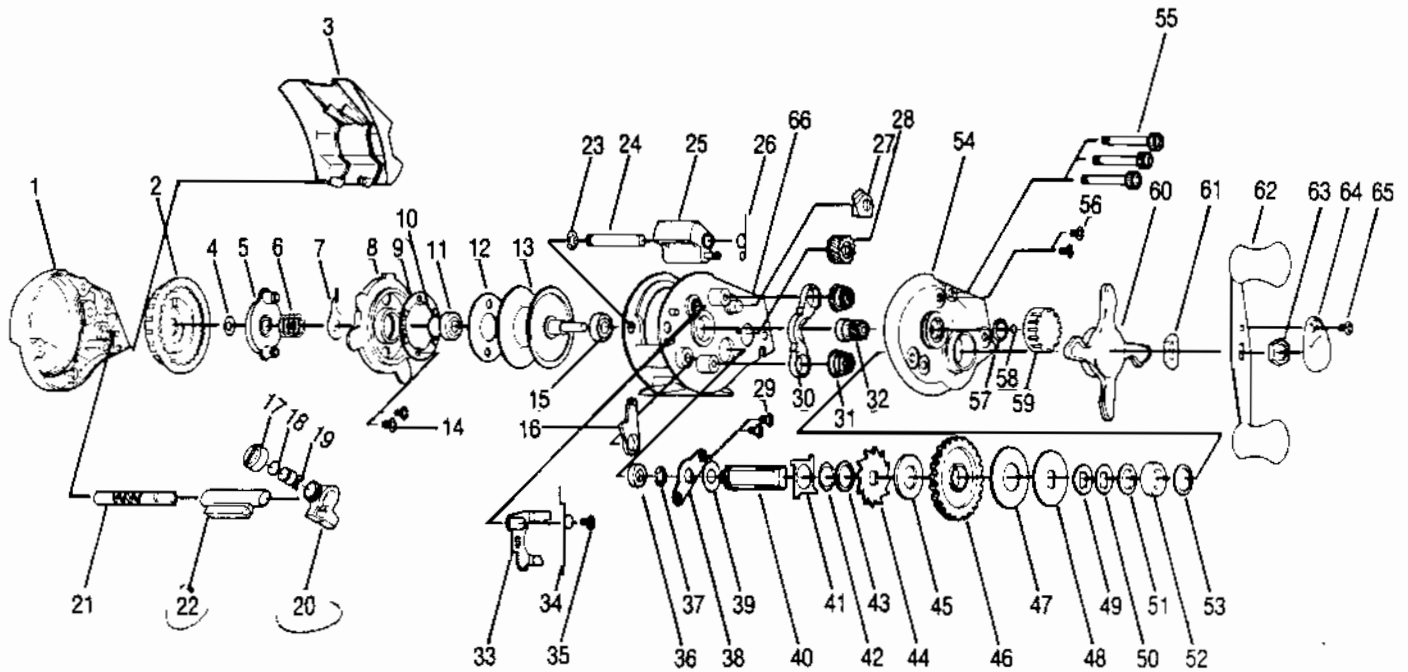

Key No.	Part No.	Description	Key No.	Part No.	Description
1	WW023	LEFT SIDE COVER	35	WW076	SCREW-RELEASE SLIDER
2	WW026	MAGNET CONTROL DIAL	36	WW103	CRANK SHAFT BUSHING
3	WW027	HOOD	37	QW120	E-RING
4	NX105	DIAL FRICTION RING	38	WW002	RETAINER-CRANK SHAFT
5	WW028	SLIDE CAM	39	WW104	WASHER-CRANK SHAFT
6	NX071	SLIDE CAM SPRING	40	WW008	CRANK SHAFT
7	WW108	CLICKER	41	GW083	TRIP RATCHET
8	WW051	SPOOL COVER	42	WW105	WASHER-TRIP RATCHET
9	WW330	MAGNET PLATE ASSEMBLY	43	WW111	WASHER-RATCHET
10	WW082	SPOOL TENSION SHIM	44	WW091	A/R RATCHET
11	WW017	SPOOL SHAFT BUSHING	45	WW110	WASHER-DRIVE GEAR
13	WW321	SPOOL ASSEMBLY	46	WW012	DRIVE GEAR
14	QW076	SCREW	47	WW059	DRAG DISC
15	WW017	SPOOL SHAFT BUSHING	48	WW045	WASHER-DRAG
16	WW084	LINK	49	QW046	SPRING WASHER C
17	QW007	LINE GUIDE CARRIER SCREW	50	QW046	SPRING WASHER C
18	QW035	CRANK SHAFT WASHER	51	WW035	WASHER-BEARING
19	WW006	LINE GUIDE PAWL	52	WW058	BEARING
20	WW347	LINE GUIDE CARRIER	53	WW035	WASHER-BEARING
21	WW072	WORM SHAFT	54	WW024	RIGHT SIDE COVER
22	WW016	WORM SHAFT GUIDE	55	WW374	THUMB SCREW
23	QW120	E-RING	56	QW050	THUMB REST SCREW
24	WW050	THUMB BAR PIN	57	WW101	TENSION KNOB O-RING
25	WW309	THUMB BAR ASSEMBLY	58	WW032	WASHER-TENSION KNOB
26	WW022	THUMB BAR SPRING	59	WW033	TENSION KNOB
27	WW363	A/R PAWL ASSEMBLY	60	WW055	DRAG STAR
28	WW085	LEVEL WIND GEAR	61	NX054	WASHER-HANDLE
29	WW107	SCREW	62	WW318	HANDLE ASSEMBLY
30	WW025	PINION YOKE	63	QW003	HANDLE NUT
31	WW040	SPRING YOKE	64	QW034	HANDLE NUT CAP
32	WW311	PINION ASSEMBLY	65	QW123	HANDLE NUT CAP SCREW
33	WW039	RELEASE SLIDER	66	WW001	FRAME
34	WW109	SPRING-RELEASE SLIDER			

WWW.REELDR.COM

Prices subject to change without notice. Prices do not include postage and handling.

PLEASE ORDER BY PART NUMBER

Rev. 5/93

Zebco Division Brunswick Corporation, Box 270, Tulsa, OK 74101 USA 918-836-5581

