

ZEBCO MS50™

weight	19.6 oz. /556 g	
pound test	14	17* 20
yards	280	250 180
meters	156	229 165

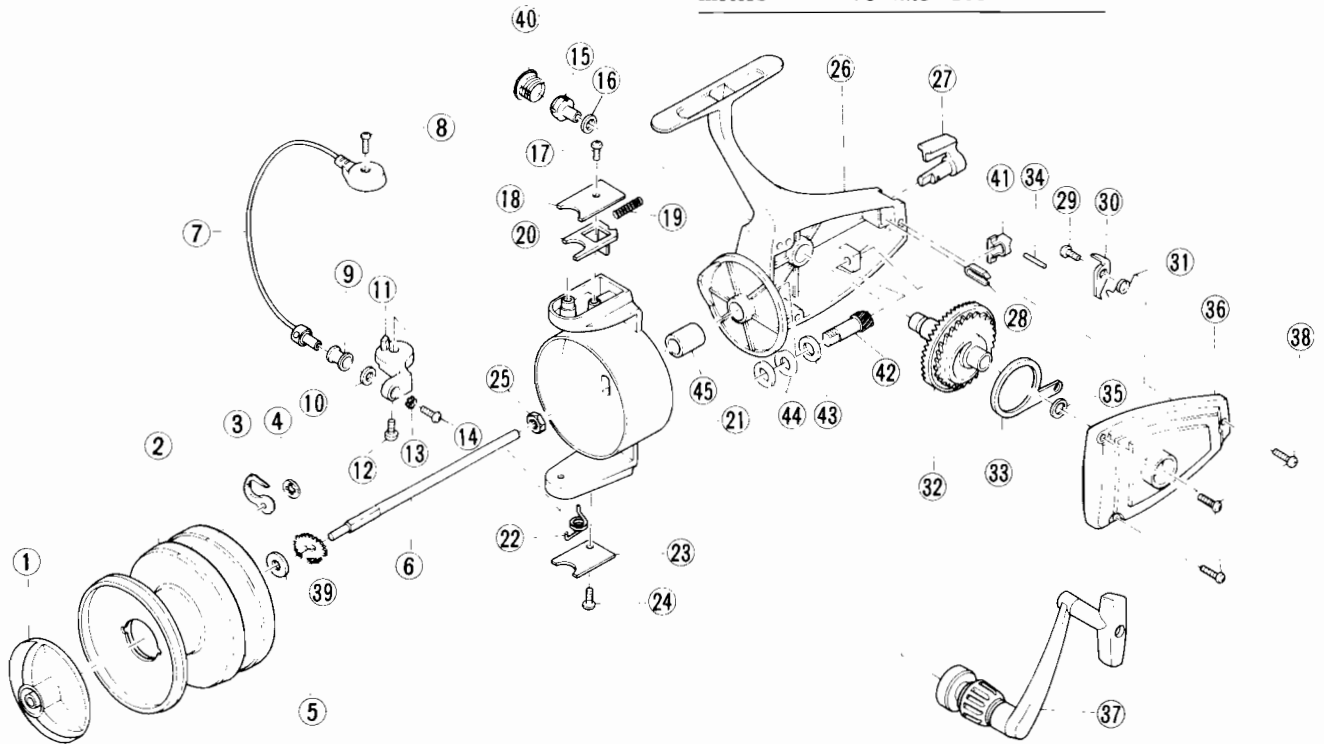

MODEL MS50

WWW.REELDR.COM

Key No.	Part No.	Description	Key No.	Part No.	Description
1	HA32-M	Drag Knob (M)	24	EB51	Bail Screw
2	HA321-M	Spool Assy(Keys 3&4 M)	25	DB6	Rotor Nut
3	CB67	Click Spring	26	HA301-M	Body (M)
4	CB68	Click Spring Retainer	27	HA59	Anti-Reverse Knob
5	EA45	Center Shaft Washer	28	HA69	Anti-Rev. Knob Spring
6	HA15	Center Shaft	29	FB80	Anti-Rev. Pawl Screw
7	FB347	Bail Assembly	30	HA63	Anti-Rev. Pawl
8	EB51	Bail Screw	31	CB61	Anti-Rev. Pawl Spring
9	FB4	Line Roller	32	HA12	Crank Gear
10	FB16	Line Roller Bushing	33	HA25	Oscillator Slider
11	EB7	Bail Arm A	34	HA62	Oscillator Slider Pin
12	EB51	Bail Screw	35	FB92	Crank Gear Shim
13	CB102	Bail Axle Washer	36	HA323-M	Side Plate Assy.(M)
14	CB108	Bail Axle Screw	37	HA318	Crank Handle Assy.
15	HA54	Handle Retainer	38	CB57	Side Plate Screw
16	FB56	Handle Retainer Washer	39	HA56	Click Gear
17	EB85	Bail Cover Screw	40	HA73	Handle Retainer Cover
18	FB24	Bail Trip Cover	41	HA53	Oscillator Slider Link
19	CB49	Bail Trip Spring	42	HA11	Pinion
20	FB19	Bail Trip Lever	43	HA81	Pinion Washer
21	HA9	Rotor	44	HA86	Bushing Washer
22	FB22	Bail Spring	45	HA28	Pinion Bushing
23	FB87	Bail Spring Cover			

PLEASE ORDER BY PART NUMBER

