

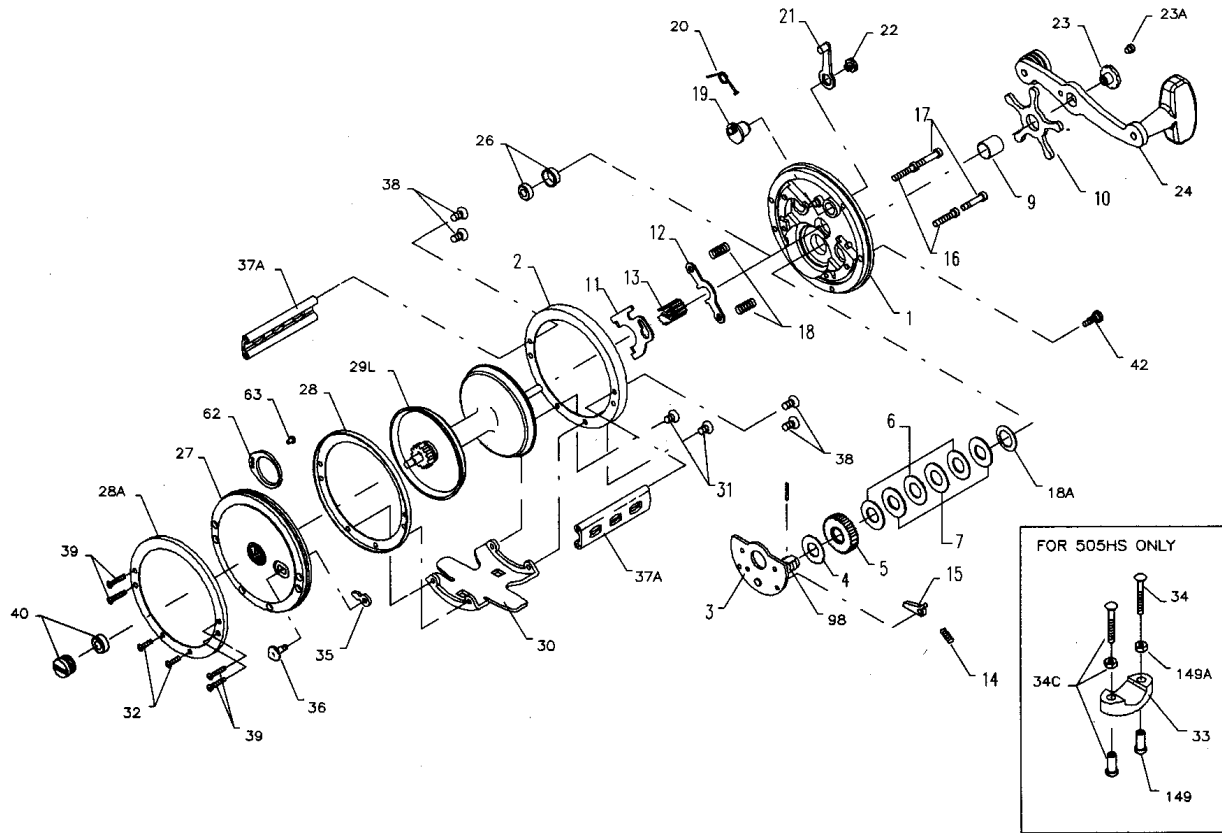

PARTS LIST FOR MODEL 505 AND 506 HS



KEY NO.	DESCRIPTION	PART NO.	KEY NO.	DESCRIPTION	PART NO.
1	Right Side Plate	1-505	26	Right Side Bearing	26-113H
	Right Side Plate	1-506	27	Left Side Plate	27-505
2	Right Side Ring	2-250	28	Left Side Ring (Inner)	28-110-I
3	Bridge w/Sleeve	3-505	28A	Left Side Ring (Outer)	28-110-O
4	Fiber Washer	4-60	29L	Aluminum Spool	29L-505
5	Main Gear	5-505		Aluminum Spool	29L-506
6	Washer	6-309	30	Stand (505 Only)	30-200
7	Washer (Metal Set)	7C-500		Stand (506 Only)	30-49
8	Tension Spring	8-60	31	R.S. Stand Screw	31-19
9	Spacing Sleeve	9-60	32	L.S. Stand Screw	39-3
10	Drag Star	10-505	33	Rod Clamp (505)	33-113
11	Eccentric Jack	11-90		Ringed Rod Clamp (505) (Optional)	*33-113
12	Pinion Yoke	12-500	34	Clamp Screw (505) (2 req.)	34-45
13	Pinion Gear	13-505	34C	Clamp Screw w/Nuts (505)	34C-45
14	Dog Spring	14-500	35	Click Tongue	35-60
15	Dog	15-500	36	Click Button	36-209
16	Lower Bridge Screw	16-60	37A	Spacer Bar	37A-500
17	Upper Bridge Screw	17-60		Spacer Bar	*37A-506
18	Clutch Spring	18-60	38	Right Side Post Screw	38-7
18A	Drag Spring Disc	18-505	39	Left Side Post Screw	39-9
19	Eccentric	19-250	40	Left Side Bearing	40-210
20	Eccentric Spring	20-60	42	Take Apart Thumb Screw	TA-200
21	Eccentric Lever	21-285	62	Click Spring	62M-309
22	Eccentric Screw	22-99	63	Click Spring Screw	31-2.5FR
23	Handle Screw	23-60	98	Gear Sleeve	98-505
23A	Handle Lock Screw	110-60	149	Clamp Nut (2 req.)	149-45
24	Handle (Complete)	24-66			

*Not Shown