

MAXXUM 65 (& SONAR) - 42"

65 lbs Thrust

24 Volt 38 Amps

42" SHAFT

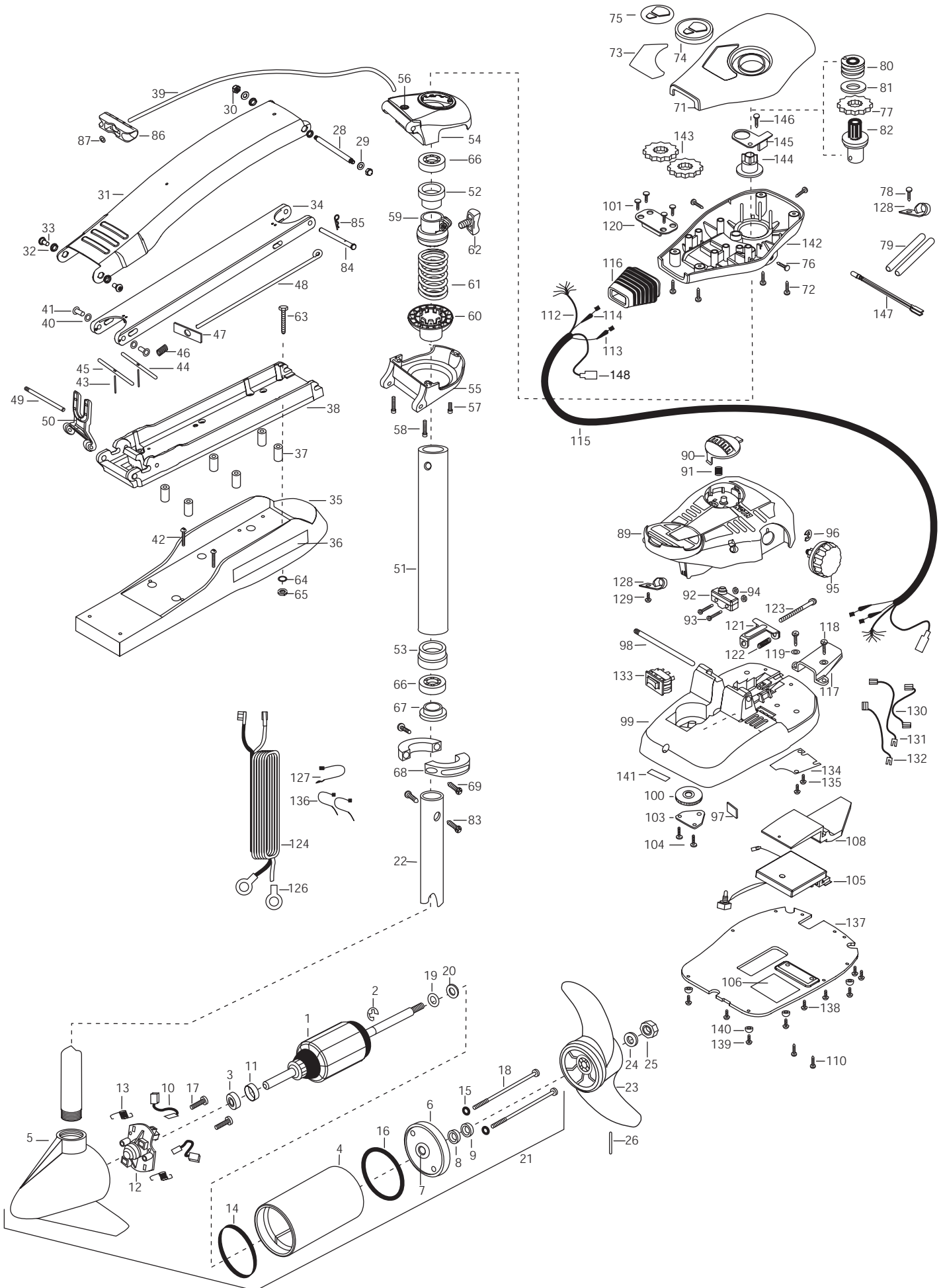

1	2-100-009	ARMATURE ASSEMBLY	47	2262703	SPRING STOP- MAXXUM	95	2260160	KNOB- SPEED CONTROL (VAR)
2	788-015	RETAINING RING	48	2153602	EYE SHAFT-2LOCKBAR STD	96	2263000	E-RING THU-ARC
3	140-010	BALL BEARING	49	2260506	HINGE-PIN HEADLESS ZINC	97	2266413	TENSION SCREW PLATE FTPEDAL
4	431-005	CENTER HOUSING ASSEMBLY	50	2293811	YOKE- MAKXUM MOUNT,POLYPROPYLENE	*98	2260511	PIN- PIVOT A/T FT PDL
5	9421-165	HOUSING BRUSH END 3.62 SONAR	■	2772012	TUBE W/BEARING RACE ASSEMBLY	99	2774550	FT PEDAL BASE/PIN ASSEMBLY
	421-065	HOUSING BRUSH END 3.62	51	2272069	TUBE OUTER-21" 4 HOLES	100	2262301	PULLEY- FOOT PEDAL
6	2-400-101	PLAIN END HOUSING ASSEMBLY	52	2266260	BEARING RACE	101	2223430	SCREW- #8X3/4 PPH TYPE 25 SS [4.EA]
7	144-049	BEARING - FLANGE (SERVICE CENTER ONLY)	53	2266220	BEARING RACE- STEEL	103	2266400	COVER- PULLEY
8	880-003	**SEAL	■	2991869	BOWGUARD ASSEMBLY- FT CTRL,FW	104	2301310	SCREW- 8-18 X 1/2 [4.EA]
9	880-006	**SEAL WITH SHIELD	54	2772315	BRACKET BASE TOP/ EYELET ASSEMBLY	105	2264008	CNTROL BOARD ASSEMBLY 24V MAX65/FC
10	188-036	BRUSH ASSEMBLY [2.EA]	*55	2991999	BRKT BOTTOM/BEARING FW ASSEMBLY	106	2365107	INSULATING PAD (2.3X3.2)
11	725-050	BRUSH RETENTION- PAPER TUBE	56	2772352	EYELET- KIT	108	2264018	HEAT SINK- MACH, MAX FTL
12	738-036	BRUSH PLATE W/HOLDER	57	2263402	SCREW- 1/4-20 X 3/4" ZINC	110	2263447	SCREW- 8-32 X 1" [2.EA]
13	975-040	SPRING - TORSION [2.EA]	58	2263404	SCREW-1/4-20 X 2 1/4 SCHP SS [2.EA]	112	2261219	WIRE HARNESS AT & MAX
14	337-036	**GASKET	59	2261525	SPRING SLEEVE- UPPER	113	2267500	CABLE ASSEMBLY- RIGHT (5')
15	701-008	**O-RING, THRU-BOLT [2.EA]	60	2261535	SPRING SLEEVE- LOWER	114	2267510	CABLE ASSEMBLY- LEFT (5')
16	701-081	**O-RING	61	2262706	SPRING- BOWGUARD, NIK PL	115	2265430	CABLE JACKET (5')
17	830-007	SCREW-8-32 [2.EA]	62	2011365	SCREW- COLLAR/NEW KNOB	116	2265110	BOOT- CONTROL BOX
18	830-008	THRU-BOLT 10-32X9.2 [2.EA]	■	2994830	BAG ASSEMBLY- MAXXUM	117	2265115	BOOT- FOOT PEDAL BASE
19	990-067	WASHER- STEEL THRUST	*63	2263431	SCREW- 1/4-20 X 3.5 PPH [6.EA]	118	2372100	SCREW- 8-18X5/8 THD [2.EA]
20	990-070	WASHER- NYLATRON	*64	2261713	WASHER- 1/4 FLAT S/S [6.EA]	119	2261714	WASHER- MAXXUM FT PDL [2.EA]
21	2098030 / 2108030	MOTOR ASSEMBLY / SONAR	*65	2263103	NUT- 1/4-20 NYLOCK-JAM SS [6.EA]	120	2261901	BRACKET- CONDUIT
22	2032061	TUBE- COMPOSITE W/CSK HOLE 43-3/4	66	2266000	BEARING BALL- STEEL [2.EA]	121	2263210	BRACKET- CONDUIT ADJUST
■	1378122	PROPELLER KIT	*67	2266115	BEARING CONE	122	2262720	SPRING- CONDUIT ADJUST
23	2091150	PROPELLER W.WEDGE	*68	2261619	COLLAR HALF- ZINC [2.EA]	123	2263463	SCREW- 1/4-20X2" STL PPH
24	2151726	WASHER-5/16 SS	*69	2263452	SCREW- 1/4-20X3/4 [2.EA]	124	2261227	LEADWIRE- A/T VARIABLE
25	2053101	NUT-PROP NYLOC	71	2260283	CONTROL BOX COVER- MAXXUM	126	2020700	TERMINAL RING- 3/8" [2.EA]
26	2092600	PIN-DRIVE	72	2372100	SCREW- 8-18 X 5/8 THD [4.EA]	127	2256300	TIE WRAP- 5.5' BLACK
28	2262605	PIN- BWGRD UPPER THREADED ZP	73	2265620	DECAL- COVER MAX65/FC	128	2263201	CLAMP WIRE HARNESS MICRO [2.EA]
29	9908236	WASHER- 1/4 FLAT ZINC [2.EA]	74	2260150	POINTER DISC TRNSLCNT RED	129	2332103	SCREW- 6-20X3/8 THD (SS)
30	2223100	NUT- TENSION 5/16-18 SS [2.EA]	75	2265800	DECAL- INDICATOR	130	2260316	CONNECTING WIRE (VAR.SPD)
■	2771840	MOUNT- BOW ASSEMBLY, STD FW MAX	76	2053414	SCREW- 8-32 X 1/2 TRI-LOBE [3. EA]	131	2260312	WIRE- BLK W/WHT STRP 19 -1/4"
31	2264241	ARM-UPPER STD FW	77	2267800	GEAR- INDICATOR	132	2260323	WIRE- BLK W/GRN STP VARIABLE
32	2293501	BUSHING- STAINLESS STEEL [4.EA]	78	2301310	SCREW- 8-18 X 1/2	133	2254031	SWITCH- MOM/OFF/CON
33	2263500	BOLT- SHOULDER MAXXUM [2.EA]	79	2355410	SHRINK TUBE- 3/8 OD X 2" [2.EA]	134	2266412	SWITCH PLATE- FT PEDAL
34	2774315	ARM-LOWER ASSEMBLY,STD,FW,EXTRA [INCLUDES 39, 43-47, 86,87]	80	2232360	PULLEY- CABLE DRUM	135	2332103	SCREW- 6-20X3/8 THD SS [2.EA]
			81	2261730	WASHER- NYLON A/T CON	136	2256301	TIE WRAP- 5.5" WHITE [2.EA]
35	2263912	MOTOR REST (STD) FW	82	2996246	TOP BEARING RACE /PINION DRIVE	137	2774510	BOTTOM PLATE- MAXXUM FT
36	2265514	DECAL- MAXXUM MOTOR REST [2.EA]	83	2263410	SCREW- 8-32 X 5/16 [2.EA]	138	9953104	SCREW-8 X 1/2" (SS) [5.EA]
37	2261505	SPACER- MOTOR REST [6.EA]	84	2262607	PIN- CLEVIS ZP MAXXUM BWGRD	139	2263455	SCREW- #12-14X1/2 THR FRM [4.EA]
38	2773987	BOWPLATE- W/INSERT	85	2260801	CLIP- SPRING ZP MAX BG	140	2265126	BUMPER PAD- FOOT PEDAL [4.EA]
39	2251601	ROPE (40"), MAXXUM MOUNT	86	2150400	PULL- GRIP	141	2266610	DECAL- ON/OFF SWITCH
40	2261708	WASHER- 3/8X1/2X.010 SS [2.EA]	87	2151700	WASHER- EYE SHAFT(.562 OD)	142	2262535	CONTROL BOX- PLASTIC
41	2236000	BEARING NYLINER [2.EA]	89	2790002	FOOT PEDAL/PLUG ASSEMBLY	143	2267800	GEAR- INDICATOR [2.EA]
42	2263434	SCREW, 8-18X1" PPH [2.EA]	90	2263700	PUSH- BUTTON FOOT PEDAL	144	2262220	INDICATOR- DRIVE
43	2152610	SPRING- PIN LOCKBAR [2.EA]	91	2302732	SPRING- LOWER PEDAL	145	2261905	BRACKET/INDICATOR
44	2233600	LOCK BAR- BOW MOUNT	92	2264023	SWITCH- SEALED ASSEMBLY	146	2301310	SCREW- 8-18X1/2"
45	2233602	LOCK BAR REAR - ZINC	93	2262114	SCREW- MOUNTING/SWITCH [2.EA]	147	2264015	LIGHT/INDICATOR
46	2152700	SPRING- LOCKBAR CAD.PLTD	94	2233100	NUT- SWITCH MOUNT [2.EA]	148	2211400	EXTENSION CABLE -SONAR

****Seal & Oring Kit P/N 2888460**

* This item is part of an assembly. This item cannot be sold separately due to machining and /or assembly that is required.

P/N 2264943 REV. D 7-01

MAXXUM 65 Wiring Diagram

