

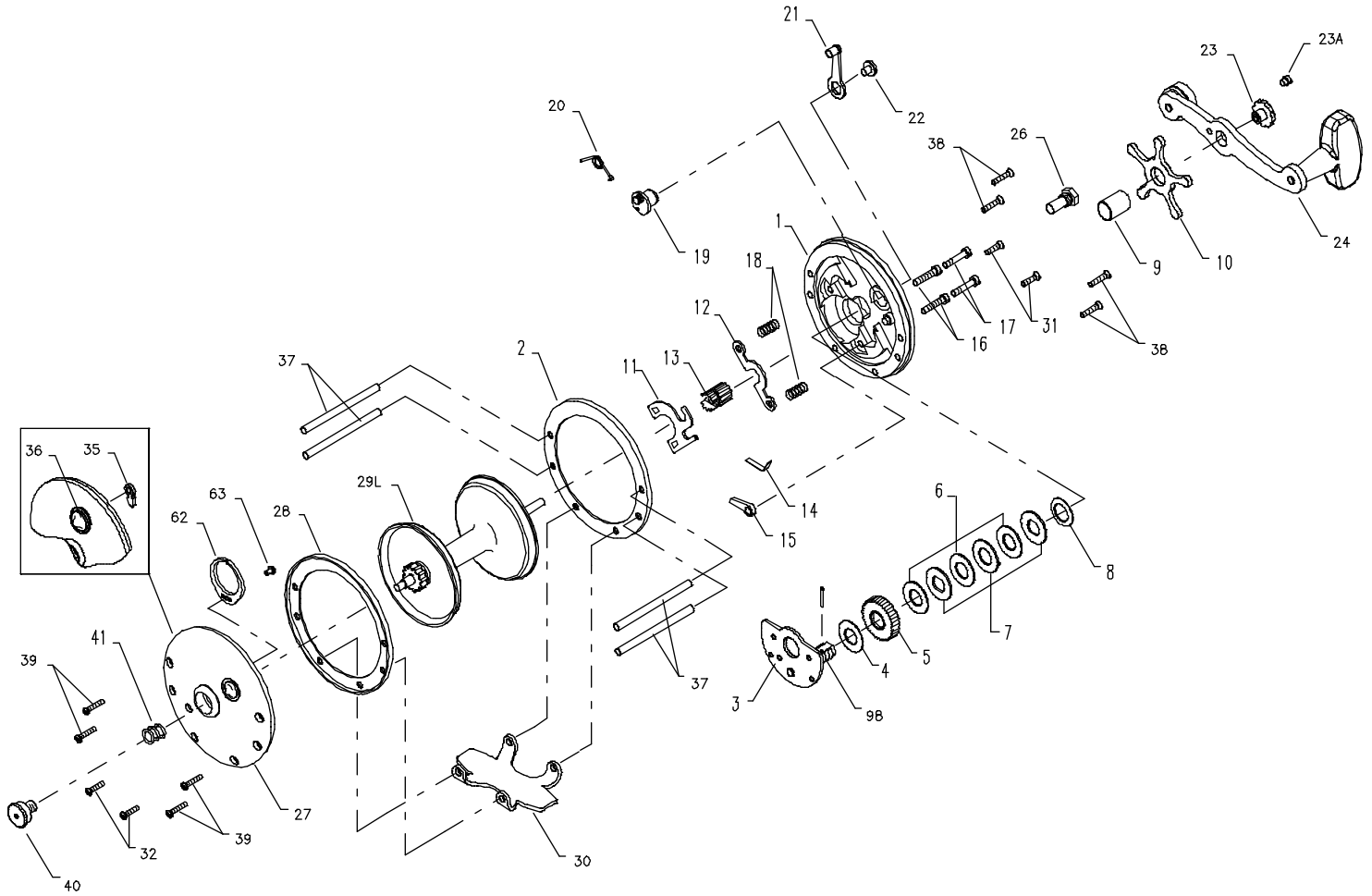

PARTS LIST FOR MODELS 155L AND 160L



KEY NO.	DESCRIPTION	PART NO.	KEY NO.	DESCRIPTION	PART NO.
1	Right Side Plate	1-155	23A	Handle Lock Screw	110-60
	Right Side Plate	1-160	24	Handle	24-155
2	Right Side Ring	2-155		Handle	24-160
3	Bridge w/Sleeve	3-155	26	Right Side Bearing	26-155
4	Fiber Washer	4-155	27	Left Side Plate	27-155
5	Main Gear	5-155	28	Left Side Ring	2-155
6	Drag Washer (3 req.)	6-155	29	Spool (155L)	29L-200
7	Metal Washer Set	7C-155		Spool (160L)	29J-150
8	Tension Spring	8-60	30	Stand	30-155
9	Spacing Sleeve	9-60		Stand (160L)	30-65
10	Star Drag Wheel	10-60	31	R.S. Stand Screw (2 req.)	32-22
11	Eccentric Jack	11-155	32	L.S. Stand Screw (2 req.)	32-14
12	Pinion Yoke	12-155	35	Click Tongue	35-155
13	Pinion	13-155	36	Click Button	36-155
14	Dog Spring	14-155	37	Frame Post	37-155
15	Dog	15-155		Frame Post	37-160
16	Lower Bridge Screw	16-60	38	Right Side Post Screw (4 req.)	38-8
17	Upper Bridge Screw	17-60	39	Left Side Post Screw (155L) (4 req.)	38-8
18	Clutch Spring	18-60		Left Side Post Screw (160L) (4 req.)	39-4
19	Eccentric	19-155	40	Left Side Bearing	40-60
20	Eccentric Spring	20-155	41	Left Side Bearing Spring	41-60
21	Eccentric Lever	21-155	62	Click Spring	62M-209
22	Eccentric Screw	22-60	63	Click Spring Screw	31-2.5FR
23	Handle Screw	23-60	98	Gear Sleeve	98-155